

# **Aitkin County Budget Hearing For Year Payable 2013**

Compiled by the Aitkin County Auditor's Office

Presented December 4, 2012

Kirk Peysar, County Auditor  
209 2<sup>nd</sup> Street NW Rm 202  
Aitkin MN 56431  
218-927-7354

## Table of Contents

Notice of Proposed Total Budget and Property Taxes.....	3
Budget and Levy Hearing Meeting Agenda.....	4
Revenues by Department – Minus Tax Levy.....	5
Expenditures by Department.....	6
Graph – General Revenue Fund Expenditures.....	8
Graph – Road & Bridge Expenditures.....	9
Graph – Health & Human Services Expenditures.....	10
Revenues to Expenditures by Department.....	11
Projected 2013 Revenues to Fund 2013 County Expenditures.....	13
Aitkin County Fund Balance Report.....	14
Graph – General Revenue Fund Income Source .....	15
Graph – Road & Bridge Fund Income Source.....	16
Graph – Health & Human Services Fund Income Source.....	17
Aitkin County Budgets and Levies.....	18
Operating Expense Revenue Fund.....	19
Graph – Wages and Benefits.....	21
Graph – Revenue Fund Operating Expenses.....	22
Graph – Road & Bridge Fund Operating Expenses.....	23
Graph – Health & Human Services Operating Expenses.....	24

## Notice of Proposed Total Budget and Property Taxes

The Aitkin County Board of Commissioners will hold a public hearing on its budget and on the amount of property taxes it is proposing to collect to pay for the costs of services the county will provide in 2013.

**SPENDING:** The total budget amounts below compare the county's 2012 total actual budget with the amount the county proposes to spend in 2013.

2012 Total <u>Actual Budget</u>	Proposed 2013 <u>Budget</u>	Change from <u>2012-2013</u>
\$30,156,700	\$25,400,916	-15.8%

**TAXES:** The property tax amounts below compare that portion of the current budget levied in property taxes in Aitkin County for 2012 with property taxes the county proposes to collect in 2013.

2012 Property <u>Taxes</u>	Proposed 2013 <u>Property Taxes</u>	Change from <u>2012 – 2013</u>
\$11,384,171	\$11,900,000	4.5%

**LOCAL TAX RATE COMPARISON:** The following compares the county's current local tax rate, the county's tax rate for 2013 if no tax levy increase is adopted, and the county's proposed tax rate for 2013.

2012 <u>Tax Rate</u>	2013 Tax Rate if <u>NO Levy Increase</u>	2013 Proposed <u>Tax Rate</u>
38.860%	39.976%	41.805%

### Attend the Public Hearing

All Aitkin County residents are invited to attend the public hearing of the county board to express their opinions on the budget and on the proposed amount of 2013 property taxes. The hearing will be held on:

Tuesday, December 4th, at 6:05 p.m.  
Aitkin County Courthouse  
209 Second Street Northwest  
Aitkin, Minnesota 56431

If discussion of the budget cannot be completed, a time and place for continuing the discussion will be announced at the hearing. You are also invited to send your written comments to:

Aitkin County Board, Aitkin County Courthouse  
209 Second Street Northwest, Aitkin, MN 56431

**AITKIN COUNTY**  
**Budget and Levy Hearing Meeting Agenda**  
**December 4, 2012**  
**6:05 P.M.**

**The purpose of this meeting is to discuss the 2013 proposed county budget and the 2013 proposed property tax levy. Changes in valuation and classification are NOT part of this discussion.**

1. Introductions
2. Explanation of how budgets are developed for the purpose of the Budget and Levy meeting.
  - a. Invitation for citizen involvement in the spending decisions.
  - b. Opportunity for County to explain the necessity for expenditures.
3. J. Mark Wedel, County Board Chair, budget comments
4. Breakdown of specific programs and changes from 2012 to 2013.
5. Source of revenue for County.
6. Comparison of levies for pay 2012 and pay 2013 taxes.
7. Questions, comments by taxpayers. Each taxpayer has 5 minutes to state their case.
8. Adopt final 2013 property tax levy on December 18, 2012.

**REVENUES BY DEPARTMENT - Minus Tax Levy**

Page 1

**REVENUE FUND**

<u>Department</u>	<u>2011 Adopted</u>	<u>2012 Final</u>	<u>2013 Proposed</u>	<u>2012 to 2013 Difference</u>	<u>Percent of Change</u>
Commissioners	0	0	0	0	0.0%
Court Administration	0	150	0	(150)	0.0%
County Auditor	256,830	283,830	281,630	(2,200)	-0.8%
County Treasurer	31,900	31,900	32,900	1,000	3.1%
County Assessor	166,432	169,496	179,498	10,002	5.9%
Central Services	1,909,500	1,592,000	1,308,500	(283,500)	-17.8%
Motor Pool	38,500	38,500	36,000	(2,500)	-6.5%
MIS	13,374	39,574	48,674	9,100	23.0%
Administration	0	0	0	0	0.0%
Elections	0	650	0	(650)	0.0%
County Attorney	46,940	56,707	65,181	8,474	14.9%
County Recorder	219,231	234,231	275,889	41,658	17.8%
Courthouse Maintenance	20,000	20,000	20,000	0	0.0%
County Buildings	65,000	65,000	0	(65,000)	-100.0%
Veteran Service Officer	9,200	9,200	12,200	3,000	32.6%
Planning & Zoning Office	238,994	260,954	256,348	(4,606)	-1.8%
Enforcement	226,400	197,700	200,200	2,500	1.3%
Sheriff Contingency	0	0	0	0	0.0%
Snowmobile Grant	6,777	6,757	6,430	(327)	-4.8%
Boat & Water Safety	30,700	30,700	31,000	300	1.0%
ATV	7,082	14,165	14,165	0	0.0%
Forfeitures	0	0	0	0	0.0%
Corrections	333,800	324,400	324,700	300	0.1%
Community Corrections	0	33,443	33,693	250	0.0%
Enhanced 911 System	88,000	96,000	96,000	0	0.0%
Crime Victim Grant	43,172	43,372	42,647	(725)	-1.7%
Sobriety Court	0	0	0	0	0.0%
Emergency Management	21,800	21,000	19,300	(1,700)	-8.1%
Environmental Health	71,000	72,000	72,000	0	0.0%
Solid Waste	58,550	59,700	59,700	0	0.0%
Water Wells	5,745	5,745	5,745	0	0.0%
County Parks	519,000	535,000	563,000	28,000	5.2%
Extension	3,000	3,000	250	(2,750)	-91.7%
Economic Development	49,630	49,630	49,630	0	0.0%
<b>Total</b>	<b>4,480,557</b>	<b>4,294,804</b>	<b>4,035,280</b>	<b>(259,524)</b>	<b>-6.0%</b>

**ROAD & BRIDGE FUND**

	<b>6,527,800</b>	<b>7,987,540</b>	<b>5,383,680</b>	<b>(2,603,860)</b>	<b>-32.6%</b>
--	------------------	------------------	------------------	--------------------	---------------

**HEALTH & HUMAN SERV FUND**

All Departments	<b>3,276,908</b>	<b>3,279,646</b>	<b>3,377,490</b>	<b>97,844</b>	<b>3.0%</b>
-----------------	------------------	------------------	------------------	---------------	-------------

<b>GRAND TOTAL</b>	<b>14,285,265</b>	<b>15,561,990</b>	<b>12,796,450</b>	<b>(2,765,540)</b>	<b>-17.8%</b>
--------------------	-------------------	-------------------	-------------------	--------------------	---------------

**EXPENDITURES BY DEPARTMENT****REVENUE FUND**

<b><u>Department</u></b>	<b><u>2011 Adopted</u></b>	<b><u>2012 Final</u></b>	<b><u>2013 Final</u></b>	<b><u>2012 to 2013 Difference</u></b>	<b><u>Percent of Change</u></b>
Commissioners	220,428	229,108	239,298	10,190	4.4%
Court Administration	76,000	100,000	108,500	8,500	8.5%
County Auditor	518,302	554,761	569,073	14,312	2.6%
Internal Audit	63,000	65,000	65,000	0	0.0%
County Treasurer	210,894	219,794	226,654	6,860	3.1%
County Assessor	731,082	755,914	782,466	26,552	3.5%
Central Services	236,174	226,981	251,431	24,450	10.8%
Motor Pool	30,243	28,571	29,861	1,290	4.5%
MIS	463,052	509,495	528,764	19,269	3.8%
Administration	308,911	317,936	339,616	21,680	6.8%
Elections	66,389	138,678	78,760	(59,918)	-43.2%
County Attorney	844,353	844,480	869,681	25,201	3.0%
County Recorder	220,799	223,619	272,179	48,560	21.7%
Courthouse Maintenance	333,680	340,992	340,928	(64)	0.0%
County Buildings	65,000	65,000	0	(65,000)	-100.0%
Veteran Service Officer	78,434	80,641	90,137	9,496	11.8%
Housing & Redevelopment	1,500	1,500	1,600	100	6.7%
Planning & Zoning Office	359,976	364,077	372,637	8,560	2.4%
County Coroner	50,000	50,000	58,000	8,000	16.0%
Enforcement	1,858,587	1,991,237	2,049,630	58,393	2.9%
Sheriff's Contingency	0	0	0	0	0.0%
Boat & Water Safety	89,101	74,511	76,286	1,775	2.4%
Snowmobile	41,188	30,636	32,314	1,678	5.5%
ATV	22,461	21,528	21,813	285	1.3%
Corrections	2,183,535	2,199,605	2,242,415	42,810	1.9%
Community Corrections	248,290	310,032	276,110	(33,922)	-10.9%
Enhanced 911 System	42,290	42,200	42,200	0	0.0%
Crime Victim Grant	58,132	59,805	61,935	2,130	3.6%
Sobriety Court	21,500	4,000	4,000	0	0.0%
Emergency Management	56,628	58,054	58,201	147	0.3%
Environmental Health	72,431	74,897	73,785	(1,112)	-1.5%
Solid Waste	250,009	243,296	247,637	4,341	1.8%
Water Wells	5,745	5,745	5,745	0	0.0%
Library & Historical Society	245,218	246,892	249,797	2,905	1.2%
County Parks	508,246	549,638	557,707	8,069	1.5%
Ag. Soc / S&W / Ag. Insp.	107,988	127,988	123,188	(4,800)	-3.8%
County Extension	70,883	70,888	68,429	(2,459)	-3.5%
Promotion, Airport	43,222	42,722	42,822	100	0.2%
Economic Development	84,922	86,314	88,619	2,305	2.7%
<b>Total</b>	<b>10,888,593</b>	<b>11,356,535</b>	<b>11,547,218</b>	<b>190,683</b>	<b>1.7%</b>

**ROAD & BRIDGE FUND**

<u>Department</u>	<u>2011 Adopted</u>	<u>2012 Proposed</u>	<u>2013 Proposed</u>	<u>2012 to 2013 Difference</u>	<u>Percent of change</u>
Administration	443,921	460,570	470,902	10,332	2.2%
Engineering/Construction	468,822	491,496	508,628	17,132	3.5%
Highway Maintenance	2,586,626	2,725,050	2,716,170	(8,880)	-0.3%
Capital Infrastructure	4,473,000	7,075,600	3,105,400	(3,970,200)	-56.1%
Equipment & Facilities	314,000	362,250	473,500	111,250	30.7%
<b>Total</b>	<b>8,286,369</b>	<b>11,114,966</b>	<b>7,274,600</b>	<b>(3,840,366)</b>	<b>-34.6%</b>

**HEALTH & HUMAN SERV FUND**

<u>Department</u>					
All Departments	6,150,099	6,027,449	6,169,223	141,774	2.4%
<b>Total</b>	<b>6,150,099</b>	<b>6,027,449</b>	<b>6,169,223</b>	<b>141,774</b>	<b>2.4%</b>

**DEBT SERVICE FUND**

<u>Department</u>					
General	409,750	412,750	409,875	(2,875)	-0.7%
Inter Fund Transfer		1,245,000	0	(1,245,000)	
<b>Grand Total</b>	<b>25,734,811</b>	<b>30,156,700</b>	<b>25,400,916</b>	<b>(4,755,784)</b>	<b>-15.8%</b>

# General Revenue Fund Expenditures

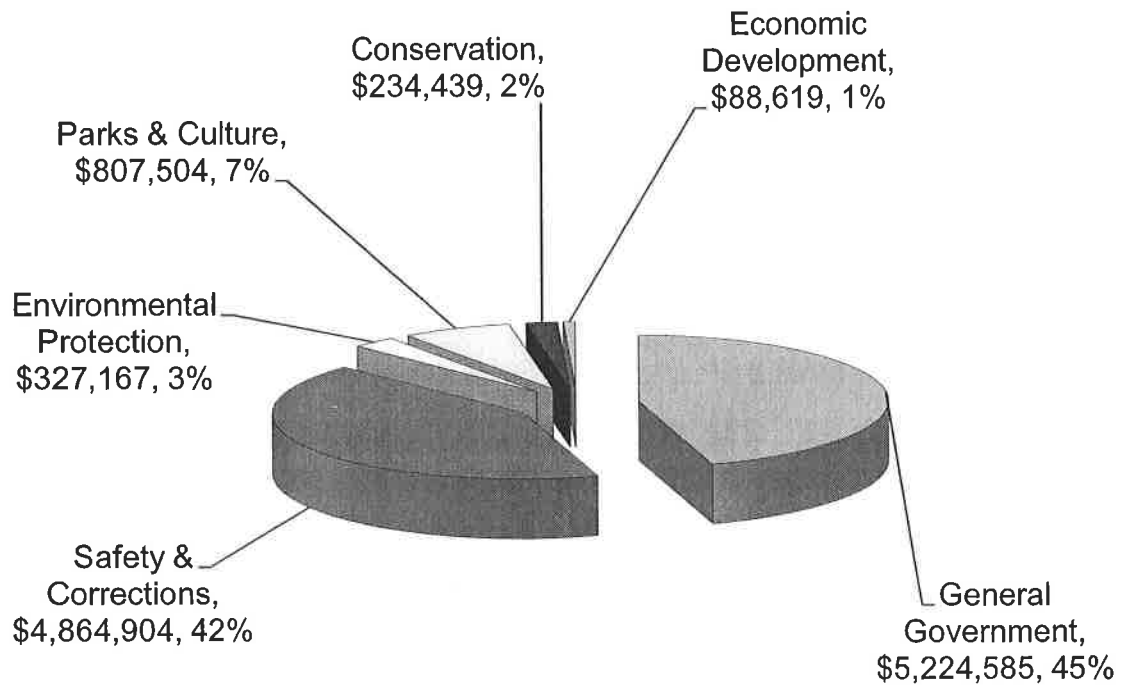



# Road & Bridge Expenditures

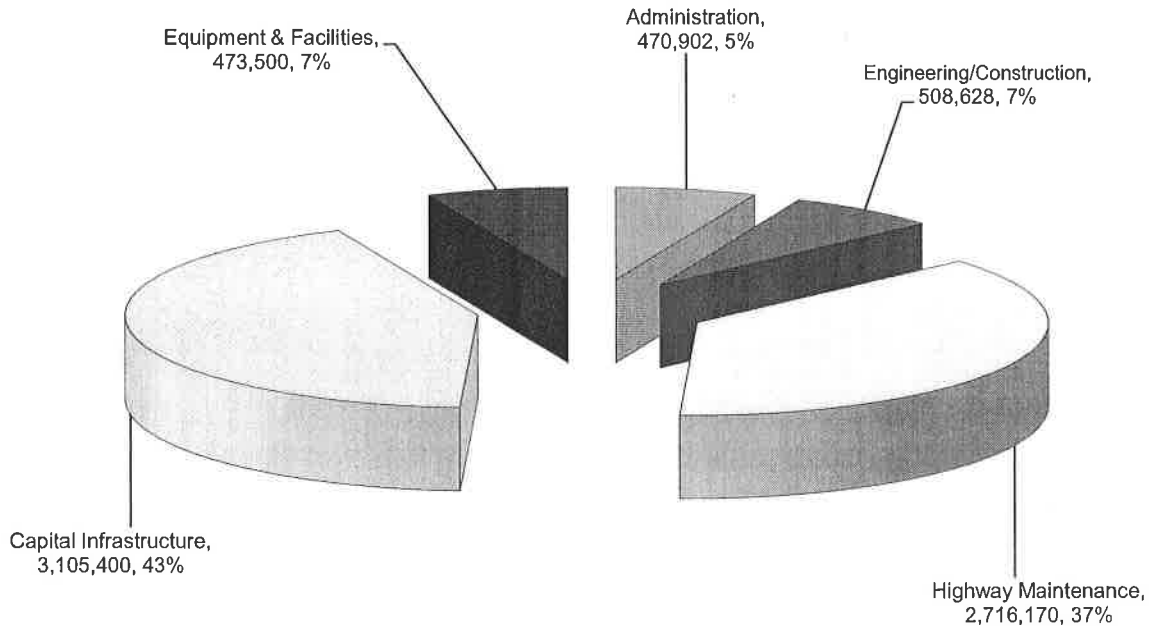

# Health & Human Services Expenditures

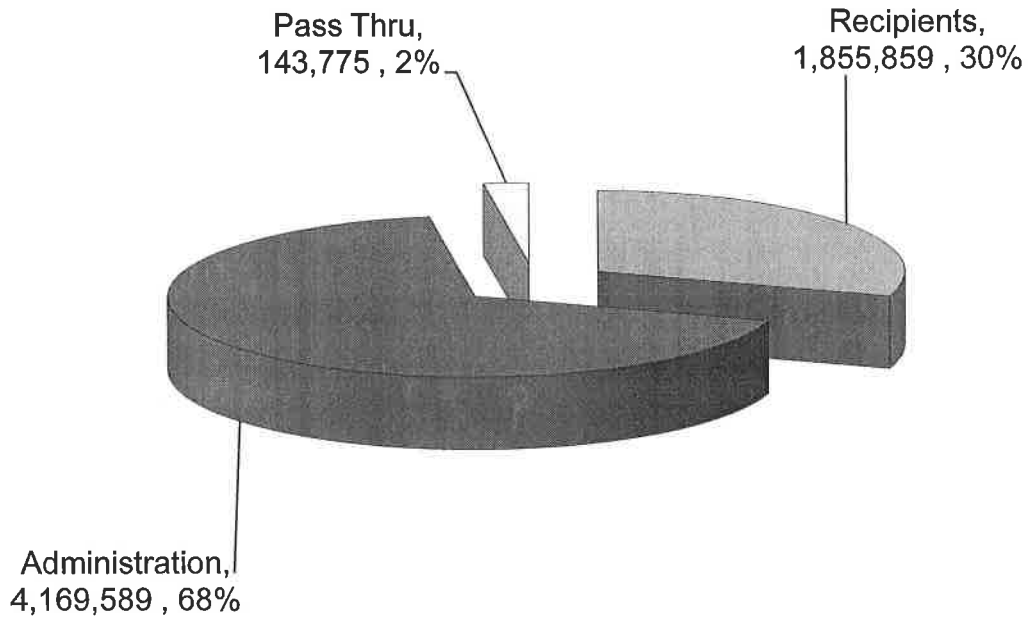

## REVENUES TO EXPENDITURES - BY DEPARTMENT

### REVENUE FUND

<u>Department</u>	<u>Adopted 2012</u>		<u>Proposed 2013</u>	
	<u>Revenues</u>	<u>Expenditures</u>	<u>Revenues</u>	<u>Expenditures</u>
Commissioners	0	229,108	0	239,298
Court Administration	150	100,000	0	108,500
County Auditor	283,830	554,761	281,630	569,073
Internal Audit	0	65,000	0	65,000
County Treasurer	31,900	219,794	32,900	226,654
County Assessor	169,496	755,914	179,498	782,466
Central Services	1,592,000	226,981	1,308,500	251,431
Motor Pool	38,500	28,571	36,000	29,861
MIS	39,574	509,495	48,674	528,764
Administration	0	317,936	0	339,616
Elections	650	138,678	0	78,760
County Attorney	56,707	844,480	65,181	869,681
County Recorder	234,231	223,619	275,889	272,179
Courthouse Maintenance	20,000	340,992	20,000	340,928
County Buildings	65,000	65,000	0	0
Veteran Service Officer	9,200	80,641	12,200	90,137
Housing & Redevelopment	0	1,500	0	1,600
Planning & Zoning Office	260,954	364,077	256,348	372,637
County Coroner	0	50,000	0	58,000
Enforcement	197,700	1,991,237	200,200	2,049,630
Sheriff Contingency	0	0	0	0
Snowmobile Grant	6,757	74,511	6,430	32,314
Boat & Water Safety	30,700	30,636	31,000	76,286
ATV	14,165	21,528	14,165	21,813
Forfeitures	0	0	0	0
Corrections	324,400	2,199,605	324,700	2,242,415
Community Corrections	33,443	310,032	33,693	276,110
Enhanced 911 System	96,000	42,200	96,000	42,200
Crime Victim Grant	43,372	59,805	42,647	61,935
Juvenile Diversion Project	0	0	0	0
Sobriety Court	0	4,000	0	4,000
Emergency Management	21,000	58,054	19,300	58,201
Environmental Health	72,000	74,897	72,000	73,785
Solid Waste	59,700	243,296	59,700	247,637
Water Wells	5,745	5,745	5,745	5,745
Library & Historical Society	0	246,892	0	249,797
County Parks	535,000	549,638	563,000	557,707
Ag. Soc / S&W / Ag. Insp.	0	127,988	0	123,188
County Extension	3,000	70,888	250	68,429
Promotion, Airport	0	42,722	0	42,822
Economic Development	49,630	86,314	49,630	88,619
<b>Total</b>	<b>4,294,804</b>		<b>4,035,280</b>	
<b>Tax Levy</b>	<b>6,198,467</b>		<b>6,865,091</b>	
<b>Total</b>	<b>10,493,271</b>	<b>11,356,535</b>	<b>10,900,371</b>	<b>11,547,218</b>

**REVENUES TO EXPENDITURES - BY DEPARTMENT, Cont'd**

**ROAD & BRIDGE FUND**

<b><u>Department</u></b>	<b>Adopted 2012</b>		<b>Proposed 2013</b>	
	<b><u>Revenues</u></b>	<b><u>Expenditures</u></b>	<b><u>Revenues</u></b>	<b><u>Expenditures</u></b>
General	7,987,540		5,383,680	
Administration		460,570		470,902
Engineering/Construction		491,496		508,628
Highway Maintenance		2,725,050		2,716,170
Capital Infrastructure		7,075,600		3,105,400
Equipment & Facilities		362,250		473,500
<b>Total</b>	<b>7,987,540</b>	<b>11,114,966</b>	<b>5,383,680</b>	<b>7,274,600</b>
<b>Tax Levy</b>	<b>2,312,846</b>		<b>2,397,920</b>	
<b>Total</b>	<b>10,300,386</b>	<b>11,114,966</b>	<b>7,781,600</b>	<b>7,274,600</b>

**Health & Human Service Fund**

<b><u>Department</u></b>				
General	3,279,646		3,377,490	
Recipients		1,813,470		1,855,859
Administration		4,104,479		4,169,589
Pass Thru		109,500		143,775
<b>Total</b>	<b>3,279,646</b>	<b>6,027,449</b>	<b>3,377,490</b>	<b>6,169,223</b>
<b>Tax Levy</b>	<b>2,747,803</b>		<b>2,791,733</b>	
<b>Total</b>	<b>6,027,449</b>	<b>6,027,449</b>	<b>6,169,223</b>	<b>6,169,223</b>

**Debt Service Fund**

<b>Tax Levy</b>	<b>436,538</b>	<b>412,750</b>	<b>369,338</b>	<b>409,875</b>
<b>Inter Fund Transfer</b>		<b>1,245,000</b>		<b>0</b>
<b>Total All Funds:</b>	<b>27,257,644</b>	<b>30,156,700</b>	<b>25,220,532</b>	<b>25,400,916</b>

**AITKIN COUNTY  
COUNTY FUNDS**

**Projected 2013 Revenues to Fund 2013 County Expenditures**

<u>Source</u>	<u>Revenue Fund</u>	<u>Road &amp; Bridge Fund</u>	<u>Health&amp;Human Service Fund</u>	<u>Debt Service Fund</u>	<u>Total</u>
<b>Property Tax Levy/CPA</b>	6,865,091	2,397,920	2,791,733	369,338	12,424,082
Other Taxes	828,500				828,500
License & Permits	65,130				65,130
Intergovernmental Revenue	1,458,752	5,320,680	2,834,057		9,613,489
Charges for Services	1,269,592	21,000	543,433		1,834,025
Interest on Investments	300,000				300,000
Miscellaneous Collections	113,306	42,000			155,306
<b>Subtotal</b>	<b>4,035,280</b>	<b>5,383,680</b>	<b>3,377,490</b>	<b>0</b>	<b>12,796,450</b>
(To) From Fund Balance	646,847	(507,000)	0	40,537	180,384
<b>Total Levy and Other Taxes &amp; Revenues</b>	<b>11,547,218</b>	<b>7,274,600</b>	<b>6,169,223</b>	<b>409,875</b>	<b>25,400,916</b>
<b>2011 Expenditure Budget</b>	<b>11,547,218</b>	<b>7,274,600</b>	<b>6,169,223</b>	<b>409,875</b>	<b>25,400,916</b>

## Aikin County Fund Balance Report

<b>Leviable</b>	<b>9/30/2011</b>	<b>9/30/2012</b>	<b>Change</b>
General Fund	\$12,420,534.18	\$9,224,339.50	(\$3,196,194.68)
Road & Bridge Fund	\$1,565,306.71	\$9,189,497.48	\$7,624,190.77
Health & Human Services Fund	\$3,911,935.14	\$4,210,244.94	\$298,309.80
Debt Service	\$375,556.75	\$403,078.48	\$27,521.73
<b>Non-Leviable</b>			
Unorganized Townships	\$536,704.72	\$512,964.47	(\$23,740.25)
Ditches	\$69,723.91	\$67,693.47	(\$2,030.44)
MCIT	\$880,794.72	\$849,580.48	(\$31,214.24)
State and Trust	\$2,995,261.15	\$2,375,205.57	(\$620,055.58)
Taxes Due Other Government Entities	\$2,736,271.54	\$264,026.93	(\$2,472,244.61)
*Taxes and Penalties	\$520,466.19	\$2,360,895.19	\$1,840,429.00
Agency and Enterprise Funds	(\$47,413.84)	\$111,398.32	\$158,812.16
<b>Totals</b>	<b>\$25,965,141.17</b>	<b>\$29,568,924.83</b>	<b>\$3,603,783.66</b>

*Please note that each of these balances include funds that are reserved or designated.*

\* - Approximately 50% of the 9/30 balance represents property taxes collected for other local units of government and will be paid out before the end of the calendar year.

# General Revenue Fund Income Source

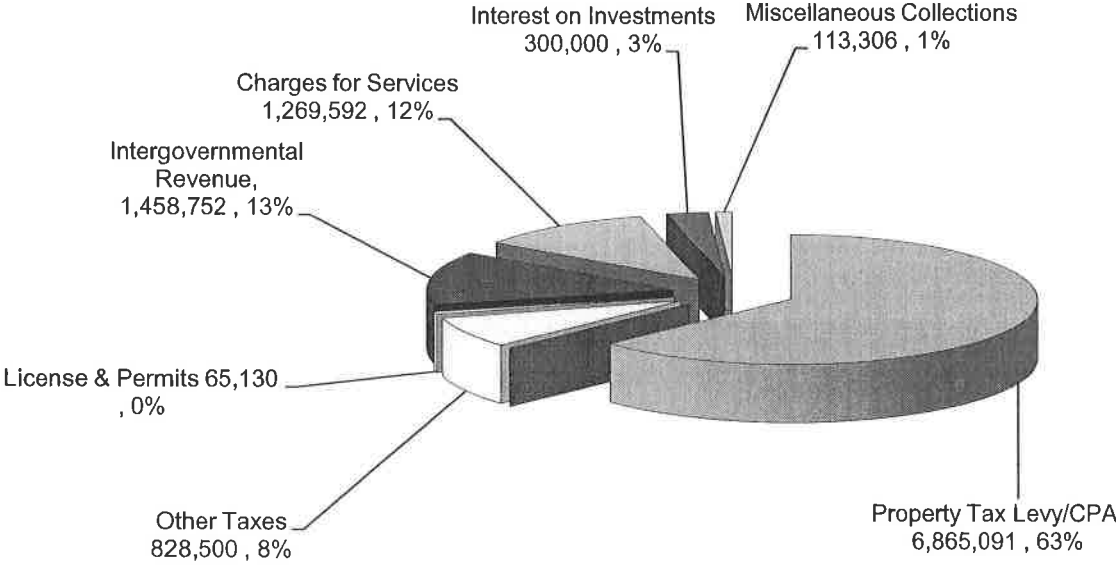

# Road & Bridge Fund Income Source

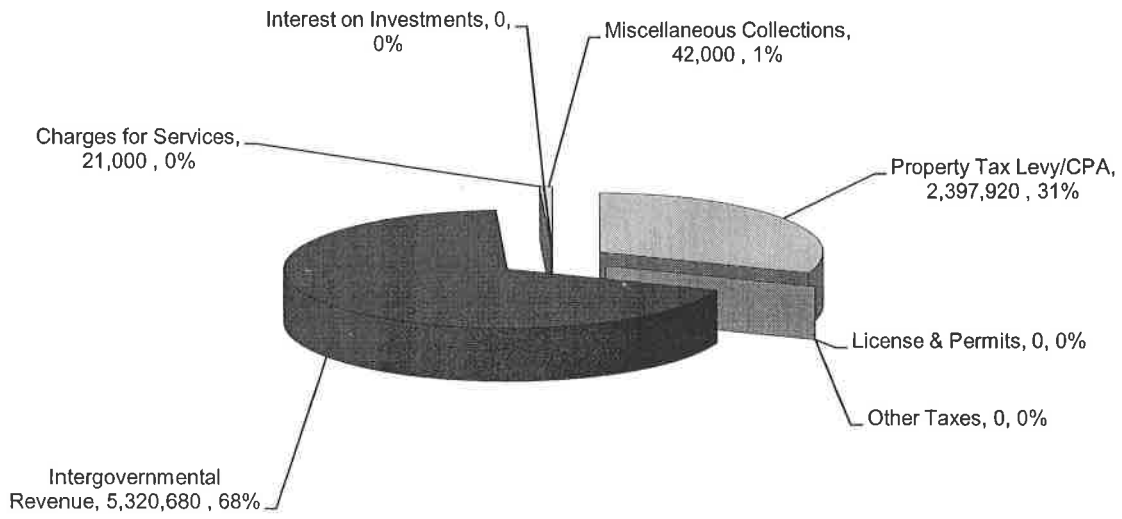



# Health & Human Services Fund Income Source

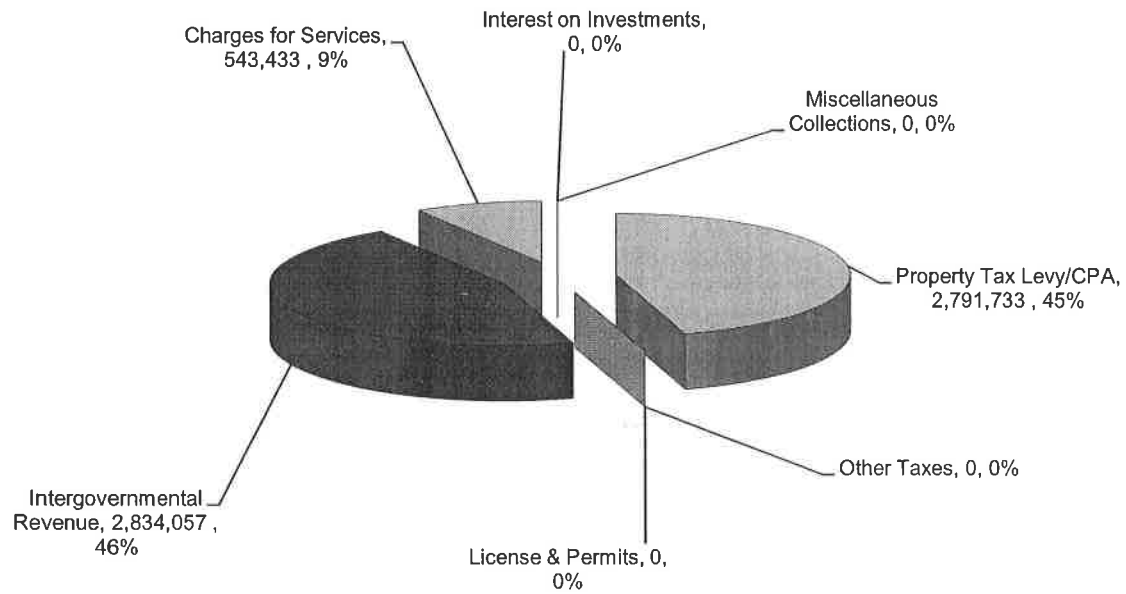

**Aitkin County  
Budgets & Levies**

	<u>Adopted 2011</u>	<u>Adopted 2012</u>	<u>Proposed 2013</u>	<u>2012 to 2013 Difference</u>	<u>Percent of Change</u>
<b>A. Budget County</b>					
General Revenue Fund	10,888,593	11,356,535	11,547,218	190,683	1.7%
Road & Bridge	8,286,369	11,114,966	7,274,600	(3,840,366)	-34.6%
Health & Human Services	6,150,099	6,027,449	6,169,223	141,774	2.4%
Debt Service	409,750	412,750	409,875	(2,875)	-0.7%
		1,245,000			
<b>Totals</b>	<b>25,734,811</b>	<b>30,156,700</b>	<b>25,400,916</b>	<b>(4,755,784)</b>	<b>-15.8%</b>
<b>B. Levy County</b>					
General Revenue Fund	6,252,897	6,198,467	6,865,091	666,624	10.8%
Road & Bridge	2,170,569	2,312,846	2,397,920	85,074	3.7%
Health & Human Services	2,663,913	2,747,803	2,791,733	43,930	1.6%
Debt Service	439,950	436,538	369,338	(67,200)	-15.4%
<b>Totals</b>	<b>11,527,329</b>	<b>11,695,654</b>	<b>12,424,082</b>	<b>728,428</b>	<b>6.2%</b>
<b>% of Budget Levy Funded</b>	<b>44.79%</b>	<b>38.78%</b>	<b>48.91%</b>		

**OPERATING EXPENSE REVENUE FUND**

<u>Department</u>	<u>Salary &amp; Benefits</u>	<u>Other Services &amp; Charges</u>	<u>Supplies</u>	<u>Cap. Out. &amp; Office Equip</u>	<u>Total</u>
Commissioners	206,948	29,500	850	2,000	239,298
Court Administration		108,500		0	108,500
County Auditor	475,648	83,875	5,350	4,200	569,073
Internal Audit		65,000		0	65,000
County Treasurer	206,754	12,850	7,050	0	226,654
County Assessor	710,166	43,900	13,100	15,300	782,466
Central Services	26,551	99,430	8,000	10,400	144,381
Motor Pool	15,011	14,550	300	0	29,861
MIS Department	346,935	126,829	8,000	47,000	528,764
Administration	289,366	44,050	6,200	0	339,616
Elections	0	18,760	60,000	0	78,760
County Attorney	823,118	27,787	15,603	3,173	869,681
County Recorder	260,934	8,645	2,100	500	272,179
Courthouse Maintenance	226,398	89,080	25,350	100	340,928
Buildings				0	0
Veteran Service Officer	67,387	15,550	7,200	0	90,137
Housing & Redvelop Brd		1,600		0	1,600
Planning & Zoning Office	288,347	77,040	4,500	2,500	372,387
County Coroner		58,000		0	58,000
Enforcement	1,565,830	211,800	120,000	152,000	2,049,630
Sheriff Contingency		0		0	0
Boat & Water Safety	56,311	10,775	5,700	3,500	76,286
Snowmobile Safety	28,084	2,230	2,000	0	32,314
ATV Safety	15,858	2,555	3,400	0	21,813
Corrections	1,794,515	243,550	199,350	5,000	2,242,415
Community Corrections	122,871	9,850	12,700	2,000	147,421
E-911		35,500	1,700	5,000	42,200
Crime Victim Grant	61,019	525	391	0	61,935
Sobriety Court		0	4,000		4,000
Emergency Management	50,591	4,010	1,600	2,000	58,201
Environmental Health	61,515	3,470	1,300	7,500	73,785
Solid Waste	145,125	28,112	1,900	2,500	177,637
Water Wells		2,745	3,000		5,745
County Parks	108,257	42,950	31,500	0	182,707
Ag. Soc / S&W / Ag. Insp.		4,800		0	4,800
County Extension	13,916	52,513	2,000	0	68,429
Economic Development	85,628	2,366	625		88,619
<b>Totals</b>	<b>\$8,053,083</b>	<b>\$1,582,697</b>	<b>\$554,769</b>	<b>\$264,673</b>	<b>\$10,455,222</b>
	<b>77%</b>	<b>16%</b>	<b>5%</b>	<b>3%</b>	<b>100%</b>

**OPERATING EXPENSE ROAD & BRIDGE FUND**

<u>Department</u>	<u>Salary &amp; Benefits</u>	<u>Other Services &amp; Charges</u>	<u>Supplies</u>	<u>Cap. Out. &amp; Office Equip.</u>	<u>Total</u>
Administration	418,702	45,200	7,000	0	470,902
Engineering/Construction	491,428	9,200	8,000	0	508,628
Highway Maintenance	1,261,870	219,500	1,234,800	0	2,716,170
Equip & Facilities	0	0	0	473,500	473,500
<b>Totals</b>	<b>\$2,172,000</b>	<b>\$273,900</b>	<b>\$1,249,800</b>	<b>\$473,500</b>	<b>\$4,169,200</b>
	<b>52%</b>	<b>7%</b>	<b>30%</b>	<b>11%</b>	<b>100%</b>
<b>HEALTH &amp; HUMAN SERV</b>	<b>\$3,619,995</b>	<b>\$450,520</b>	<b>\$59,474</b>	<b>\$39,600</b>	<b>4,169,589</b>
	<b>87%</b>	<b>11%</b>	<b>1%</b>	<b>1%</b>	<b>100%</b>
<b>DEBT SERVICE FUND</b>	<b>0</b>	<b>0</b>	<b>409,875</b>	<b>0</b>	<b>409,875</b>

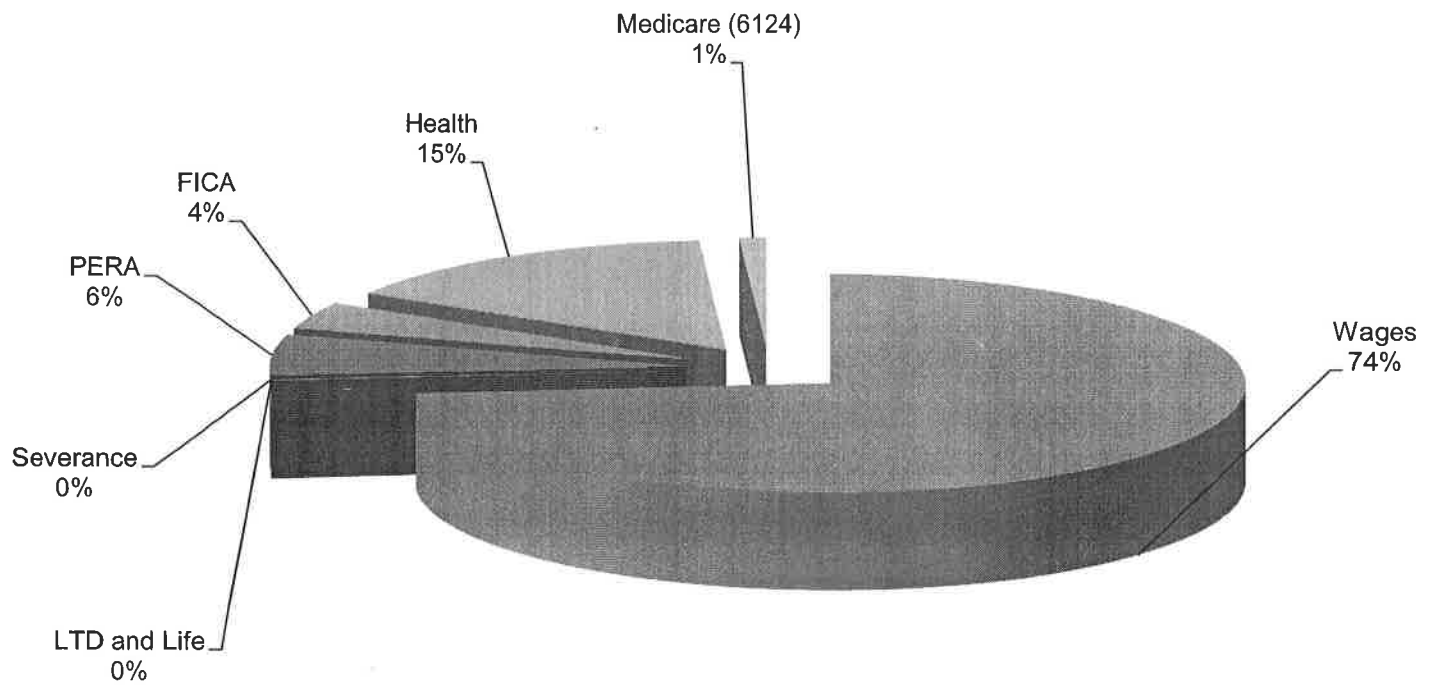

Total Wages and Benefits  
\$13,845,078

# Revenue Fund Operating Expenses

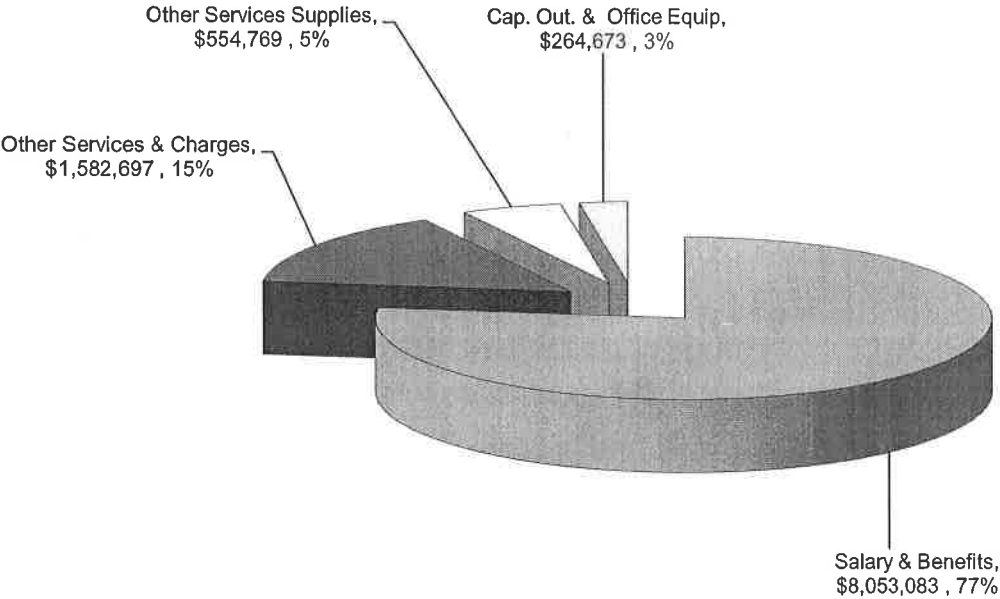

# Road & Bridge Fund Operating Expenses

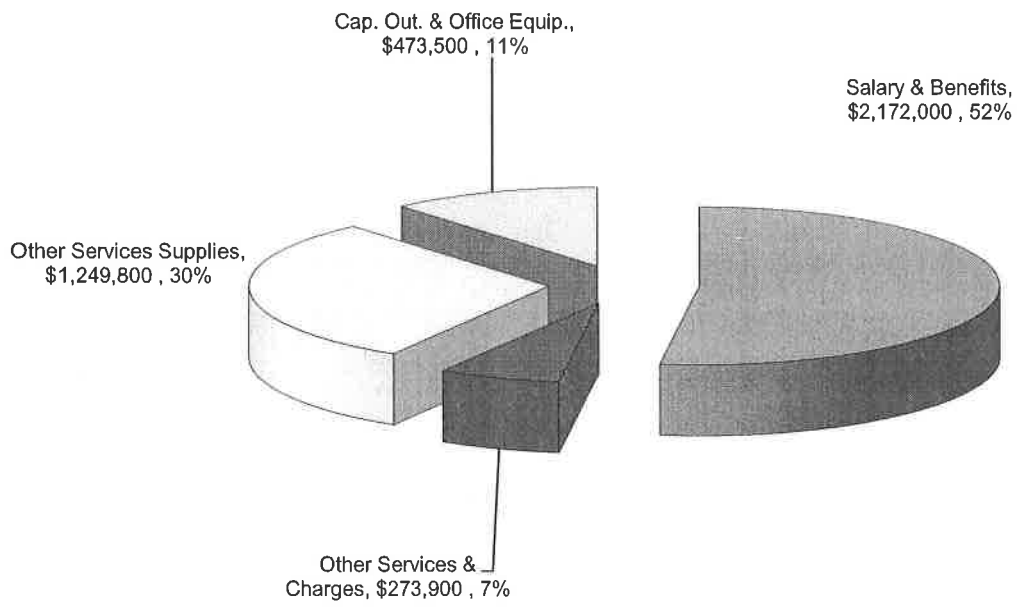

# Health & Human Services Operating Expenses

